

5MP Outdoor Bullet Network Camera with AI engine

WV-X1551LN has onboard AI functionality. AI-based high precision analysis helps surveillance operations and crime prevention operations more efficiently, whereas these operations previously required dedicated manpower.

There are 3 AI functions available through the camera: detecting suspicious changes in captured scenes, optimizing the image settings of the camera (based on captured scene analysis) for better image usability, and optimizing video compression through captured scenes to save bandwidth at 50%* lower than existing cameras while maintaining image quality.

*Compared to Smart Coding ON with H.265

Optimization of image quality and data compression using AI engine

- AI detects, identifies and determines movement.
- AI determines human faces and captures them in the most visible state.
- AI determines moving objects, identifies where there is no movement, and performs efficient data compression.

3rd party relationship

- To enable 3rd party companies to develop their applications using SDK.
- Users can freely combine applications and introduce analysis software that is the best match for their requirements.

Easy installation

- AI analysis automatically applies optimal settings, allowing you to capture high-quality images effortlessly.
- Connect the network cable to the camera body simply by opening a part of the packaging, saving you time and working space.

Key Features

- 5-megapixel images up to 30fps
- AI intelligent Auto
- Color night vision (0.0044 to 0.07 lx)
- H.265 Smart Coding
- ClearSight Coating
- FIPS140-2 CAVP compliant
 - *Using encryption module standardized by FIPS publication 140-2
- Onvif Profile G / M / S / T

Industry examples

- Public safety (City / Highway toll / Parking gate)
- Transportation (Airport / Train / Subway)
- Retail / Bank / Logistics / Education / Hospital / Building



Specifications

| | | |
|--------------------|--|--|
| Camera | Image Sensor | 1/2.8 type CMOS image sensor |
| | Minimum Illumination | Color : 0.07 lx, BW : 0.04 lx (50IRE, F1.3, Maximum shutter : Off (1/30s), AGC : 11) BW : 0 lx (50IRE, F1.3, Maximum shutter : Off (1/30 s), AGC : 11, when the IR LED is lit) Color : 0.0044 lx, BW : 0.003 lx (50IRE, F1.3, Maximum shutter : max. 16/30s, AGC : 11) *1 |
| | White Balance | ATW1/ATW2/AWC |
| | Shutter Speed | [30fps mode] 1/30 Fix to 1/10000 Fix [25fps mode] 1/25 Fix to 1/10000 Fix |
| | AI Intelligent Auto | On / Off |
| | Super Dynamic | On / Off, The level can be set in the range of 0 to 31. |
| | Dynamic Range | Max.132 dB (Super Dynamic : On, Level : 30 or more, 15fps *2) |
| | Adaptive Black Stretch | The level can be set in the range of 0 to 255. |
| | Back light compensation / High light compensation | BLC (Back light compensation) / HLC (High light compensation) / Off The level can be set in the range of 0 to 31. (only when Super dynamic / AI Intelligent Auto : Off) |
| | Fog compensation | On / Off, The level can be set in the range of 0 to 8 (only when AI Intelligent auto / auto contrast adjust : Off) |
| | Maximum gain | The level can be set in the range of 0 to 11. |
| | Color/BW (ICR) | Off / On (IR Light Off) / On (R Light On) / Auto1 (IR Light Off) / Auto2 (IR Light On) / Auto3 (SCC) |
| | IR LED Light | High / Middle / Low / Off, Maximum irradiation distance : 40 m (Approx. 131 ft) |
| | Digital Noise Reduction | The level can be set in the range of 0 to 255. |
| | Video Motion Detection (VMD) | On / Off, 4 areas available |
| | Scene Change Detection (SCD) | On / Off, 1 area available |
| | Privacy Zone | On / Off, Up to 8 zones available |
| | Image rotation*3 *4 | 0° (Off) / 90° / 180° (Upside-down) / 270° |
| Camera Title (OSD) | On / Off, Up to 20 characters (alphanumeric characters, marks) | |
| Lens | Optical zoom | 3.1x (Motorized zoom / Motorized focus) |
| | Extra optical zoom | 3.1x - 9.3x (when resolution is 640x360) |
| | Digital (electronic) zoom | Choose from 3 levels of x1, x2, x4 |
| | Focal length | 2.9 mm - 9 mm (1/8 inches - 11/32 inches) |
| | Maximum Aperture Ratio | 1 : 1.3 (WIDE) - 1 : 2.5 (TELE) |
| | Focus range | 0.3 m (11-13/16 inches) - ∞ |
| DORI *5 | Detect (25ppm / 8ft) | Wide: 46.3 m / 151.90 ft, Tele: 200.96 m / 659.32 ft |
| | Observe (62.5ppm / 19ft) | Wide: 18.52 m / 60.76 ft, Tele: 80.38 m / 263.72 ft |
| | Recognize (125ppm / 38ft) | Wide: 9.26 m / 30.38 ft, Tele: 40.19 m / 131.86 ft |
| | Identify (250ppm / 76ft) | Wide: 4.63 m / 15.19 ft, Tele: 20.1 m / 65.93 ft |
| Adjusting Angle | Ceiling mounting | Horizontal : ±180° (Adjust by horizontal (PAN) angle) Vertical : 0° to 100° (Adjust by vertical (TILT) angle) Yaw : -190° to +100° (Adjust by azimuth (YAW) angle) |
| | Wall mounting | Horizontal : ±100° (Adjust by vertical (TILT) angle)* Vertical : ±100° (Adjust by vertical (TILT) angle)* Yaw : -190° to +100° (Adjust by azimuth (YAW) angle) *You can change between horizontal and vertical angles by adjusting the horizontal (PAN) angle. |
| Browser GUI | Camera Control | Brightness, AUX On / Off |
| | Audio | Mic (Line) Input : On / Off Volume adjustment : Low / Middle / High Audio Output : On / Off Volume adjustment : Low / Middle / High |
| Network | GUI / Setup Menu Language | English, Italian, French, German, Spanish, Portuguese, Russian, Chinese, Japanese |
| | Network IF | 10Base-T / 100Base-TX, RJ45 connector |
| | Resolution*6 | [16 : 9 mode] * [4 : 3 mode] is not supported. |
| | H.265 / H.264 / JPEG (MJPEG) | 3072x1728*7, 2560x1440, 1920x1080, 1280x720, 640x360, 320x180 |
| | H.265 / H.264*8 | Transmission Mode : Constant bit rate / VBR / Frame rate / Best effort Transmission Type : Unicast port (AUTO) / Unicast port (MANUAL) / Multicast JPEG : Image Quality 10 steps |

*1 Converted value
*2 The frame rate is limited to 15 fps for level 30 or higher. The dynamic range is 108 dB typ / 30 fps for level 29 or lower.
*3 90° and 270° are invalid only in the 320x180 resolution.
*4 Following the setting angle of the rotated image, the analog output of the MONITOR OUT terminal rotates.
*5 Maximum distance at which a camera's tele and wide lens can meet DORI specifications. This value does not indicate the performance of the camera. Calculations made with the camera installed horizontally at resolution of 3072 x 1728.
*6 H.265/H.264 can be selected for each stream.
*7 Camera uses Super resolution techniques. Super resolution techniques are techniques that enhance the resolution of an image.
*8 Transmission for 4 streams can be individually set.

| | | | |
|--------------|---|--|---|
| Network | Smart Coding | Smart Facial Coding : On (Smart Facial Coding) / On (Auto VIQS) / Off *Smart Facial Coding is only available with Stream(1). GOP (Group of pictures) control : On (Frame rate control) * / On (Advanced) * / On (Mid) / On (Low) / Off *On (Frame rate control) and On (Advanced) are only available with H.265. | |
| | Audio Compression | G.726 (ADPCM) : 16 kbps / 32 kbps , G.711 : 64 kbps AAC-LC*9 : 64 kbps / 96 kbps / 128 kbps | |
| | Audio transmission mode | Off / Mic (Line) input / Audio output / Interactive (Half duplex) / Interactive (Full duplex) | |
| | Supported Protocol | IPv6 : TCP/IP, UDP/IP, HTTP, HTTPS, FTP, SMTP, DNS, NTP, SNMP, DHCPv6, RTP, MLD, ICMP, ARP, IEEE 802.1X, DiffServ, SSL/TLS*12, MQTT*12, LLDP*12 IPv4 : TCP/IP, UDP/IP, HTTP, HTTPS, RTSP, RTP, RTP/RTCP, FTP, SMTP, DHCP, DNS, DDNS, NTP, SNMP, UPnP, IGMP, ICMP, ARP, IEEE 802.1X, DiffServ, SSL/TLS*12, MQTT*12, LLDP*12 | |
| | No. of Simultaneous Users | Up to 14 users (Depends on network conditions) | |
| | SDXC/SDHC/SD Memory Card | H.265 / H.264 recording : Manual REC / Alarm REC (Pre/Post) / Schedule REC / Backup upon network failure JPEG recording : Manual REC / Alarm REC (Pre/Post) / Backup upon network failure Compatible SDXC/SDHC/SD Memory Card : Panasonic 2 GB, 4 GB*, 8 GB*, 16 GB*, 32 GB*, 64 GB**, 128 GB**, 256 GB** model *SDHC card, ** SDXC card (except miniSD card and microSD card) | |
| | Mobile Terminal Compatibility | iPad, iPhone, Android™ terminals | |
| | ONVIF Profile | G / M / S / T | |
| | Alarm | Alarm Source | 3 terminals input, VMD alarm, SCD alarm, Command alarm |
| | | Alarm Actions | SDXC/SDHC/SD memory recording, E-mail notification, HTTP alarm notification, Indication on browser, FTP image transfer, Panasonic alarm protocol output |
| Input/Output | Monitor Output (for adjustment) | VBS : 1.0 V [p-p] / 75 Ω, composite, Pin jack An NTSC or PAL signal can be outputted from camera | |
| | Audio input | ø3.5 mm stereo mini jack For microphone input : Recommended applicable microphone : Plug-in power type (Sensitivity of microphone : -48 dB±3 dB (0 dB=1 V/Pa, 1 kHz)) Input impedance : Approx. 2 kΩ (unbalanced) Supply voltage : 2.5 V ±0.5 V For line input : Input level : Approx. -10 dBV | |
| | Audio Output*10 | ø3.5 mm stereo mini jack (Audio output is monaural.) Output impedance : Approx. 600 Ω (unbalanced) Output level : -20 dBV | |
| | External I/O Terminals | ALARM IN 1 (Alarm input 1) Black & white input / Auto time adjustment input (x1), ALARM IN 2 (Alarm input 2) ALARM OUT (x1), ALARM IN 3 (Alarm input 3) AUX OUT (x1) | |
| General | Safety | UL (UL60950-1), c-UL (CSA C22.2 No.60950-1), CE, IEC60950-1 | |
| | EMC | FCC (Part15 ClassA), ICES003 ClassA, EN55032 ClassB, EN55024 | |
| | Power Source and Power Consumption | DC power supply : DC 12 V 930 mA/Approx. 11.2 W PoE (IEEE802.3af compliant) Device : DC48 V 240 mA/Approx. 11.5 W (Class 0 device) | |
| | Ambient Operating Temperature | -40 °C to +60 °C (-40 °F to +140 °F)*11 (Power On range : -30 °C to +60 °C (-22 °F to +140 °F)) | |
| | Ambient Operating Humidity | 10 to 100 % (no condensation) | |
| | Dehumidification Device | Rosahl element | |
| | Water and Dust Resistance | IP66 (IEC60529), Type 4X (UL50E), NEMA 4X compliant | |
| | Shock Resistance | IK10 (IEC 62262) | |
| | Wind Resistance | Up to 40 m/s (approx. 89 mph) | |
| | Dimensions | With adapter box : 133 mm (W) x 133 mm (H) x 377 mm (L) {5-1/4 inches(W) x 5-1/4 inches(H) x 14-27/32 inches(L)} Without adapter box : 130 mm (W) x 130 mm (H) x 337 mm (L) {5-1/8 inches(W) x 5-1/8 inches(H) x 13-9/32 inches(L)} | |
| Mass | With adapter box : 2.2 kg (4.85 lbs) Without adapter box : 1.7 kg (3.75 lbs) | | |
| Finish | Main body : Aluminum die cast and resin, i-PRO white Outer fixing screws : Stainless steel (Corrosion-resistant treatment) Front panel : Polycarbonate resin (with ClearSight coating), Clear | | |

*9 When recording audio on an SD memory card, only use AAC-LC (Advanced Audio Coding - Low Complexity).
*10 The audio output can be switched to the monitor output. Refer to the Operating Instructions on the our support web site for descriptions of how to switch the output.
*11 When using with the IR LED light constantly lit, the upper limit of the operating temperature range is +50 °C (+122 °F).
*12 It may be necessary to upgrade the firmware to use these protocols

Appearance

Unit : mm (inches)

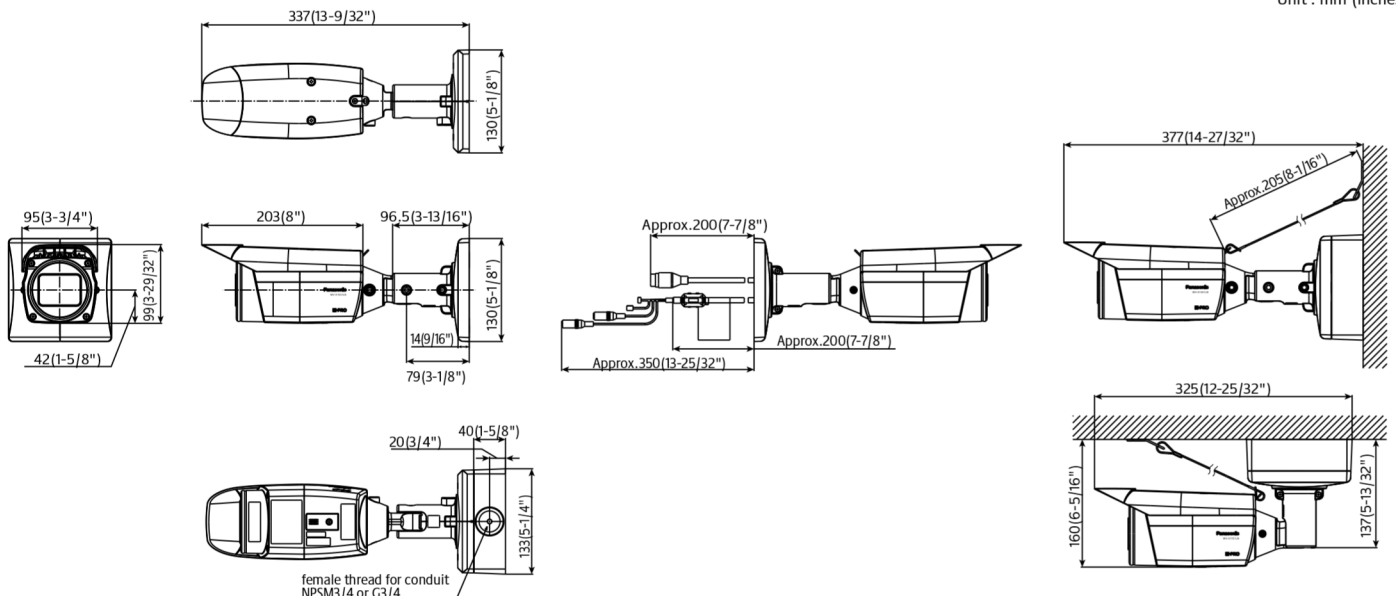

Analytics Applications (Optional Software)

Extension Software **WV-XAE200W**

AI differentiates between vehicles, motorcycles, bicycles, and people. It further detects and sends warning notifications when they enter a specified area.

AI Video Motion Detection



- It is possible to issue an alarm when a moving object enters a specified area.



- It is possible to issue an alarm when a moving object enters a specified area and stays there for a specified amount of time.



- It is possible to issue an alarm when a moving object enters a specified area and moves in the specified direction.

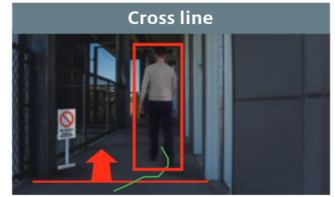

- It is possible to issue an alarm when an object moving in the specified direction crosses a specified threshold.

Extension Software **WV-XAE201W**

To protect privacy and portrait rights, it is possible to automatically apply a mosaic the entire face and figure of a person photographed by the camera.

AI Privacy Guard



Original image



Processed image



Original image



Processed image

Optional Accessories

Mount Bracket

Ceiling Mount Bracket
WV-QCL100-W
(i-PRO white)



*For indoor installation only

Pole Mount Bracket
WV-QPL500-W
(i-PRO white)



Corner Mount Bracket
WV-QCN500-W
(i-PRO white)



- Brackets are available in four colors, Fine silver, Light gray, Gray and i-PRO white. It is possible to use them in different color combinations.

Trademarks and registered trademarks

- iPad and iPhone are trademarks of Apple Inc., registered in the U.S. and other countries.
- Android is a trademark of Google LLC.
- ONVIF is trademarks or registered trademarks of Onvif Inc.
- All other trademarks identified herein are the property of their respective owners.

Important

- Safety Precaution : Carefully read the Basic Information, Installation Guide and Operating Instructions before using this product.
- Panasonic cannot be responsible for the performance of the network and/or other manufacturers' products used on the network.

- Masses and dimensions are approximate. • Specifications are subject to change without notice.

Panasonic[®]

Panasonic Corporation

Panasonic i-PRO Sensing Solutions Co., Ltd.

<https://ipro.panasonic.com>

<https://security.panasonic.com>

<https://www.linkedin.com/company/i-pro-sensing-solutions-co-ltd/>

(2A-246DA-R1)